

# RF SoP for Multi-band RF and Millimeter-wave Systems

BY M.M. TENTZERIS, J. LASKAR, J. PAPAPOLYMEROU, D. THOMPSON, S. PINEL, R.L. LI, J.H. LEE, G. DEJEAN, S. SARKAR, R. PRATAP, R. BAIRAVASUBRAMANIAN AND N. PAPAGEORGIOU

**M**iniaturization, portability, cost and performance are the primary challenges in wireless systems. The team at Georgia Tech's Packaging Research Center believes the best way to address the challenges in RF, microwave and millimeter-wave applications is by the concept called system-on-package (SoP). Recent research shows SoP to be a more feasible, low-cost solution than the system-on-chip (SoC) approach.

Although cost, electrical performance, integration density and packaging capability are often at odds with each other in RF designs, the SoP design strategy may satisfy these variables simultaneously. Thus, the use of multilayer substrates for 3-D integration of RF and mm-wave functions and modules is of great research interest.

Our research focuses mainly on advanced multilayer organic substrates using FR4 and advanced materials such as liquid crystal polymer (LCPs), as well as low-temperature cofired ceramics (LTCCs). The choice of the most suitable technology depends on application specifications such as environment, frequency of operation, performances, volume and cost. Multilayer organic substrates are widely developed and used in the high density interconnect (HDI) industry. They use an inexpensive substrate such as FR4 and a low-cost advanced epoxy and poly-

imide as dielectrics, and tend to dominate the market for high-volume applications up to GHz frequency range. LTCC is widely used for RF and mm-wave applications because of its process maturity, stability and relatively low cost. Multilayer capability of up to 20 metal layers makes LTCC attractive for 3-D integrated embedded components such as filters and antennas in a compact and cost-effective manner.

LCP is proving to be a valid alternative for high-frequency designs because of its ability to act as both the substrate and package for multilayer constructions. It is a fairly new, low-cost thermoplastic material and its performance as an organic material

is comparable to ceramic-based substrates that are widely used in RF and microwave applications (Table 1). Its dielectric constant is 3.0 at 20 GHz and increases slightly with frequency up to 110 GHz, while the loss tangent is quite small (~0.002 to 0.0045 at 110 GHz). The engineered coefficient of thermal expansion (CTE) leads to better matching to silicon or chip package and

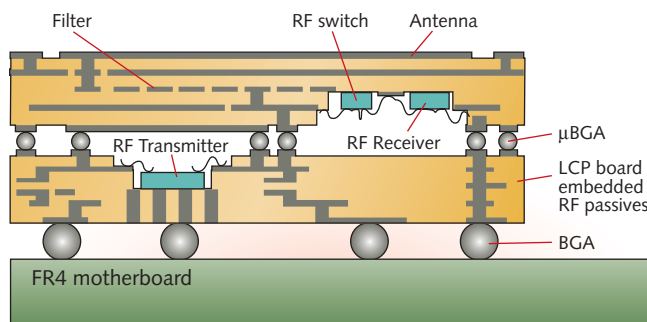

Figure 1. 3-D integrated module concept view.

provides better reliability. Low moisture absorption (~0.04 percent) enables a better stability of performances and a possible solution for hermetic RF-MEMS packaging. LCP offers a large area processing capability that leads to tremendous cost reduction compared to commonly used LTCC substrates. Using vertical space allows the passive elements in RF front ends to be efficiently integrated. However, processing challenges such as LCP-metal adhesion and bond registration have delayed widespread LCP implementation. LCP is situated as a prime technology for enabling SoP RF designs.

The loss characterization of LCP transmission lines up to W-band provides insight into its potential for mm-wave applications. Conductor-backed CPW and microchip transmission lines have been fabricated on LCP substrates between 2-8 mils (50-203 μm) and 2-5 mils (50-127 μm), with a measured insertion loss of less than 1.1 dB/cm at 110 GHz and 1.39-2.55 dB/cm at 110 GHz, respectively. LCP also has proven to be an excellent material to design high-Q spiral inductors. The measured results exhibit good quality factors as high as 90 from C to X-band, for inductance values ranging from 2 to 5 nH. The low-cost, low loss and easy integrability of LCP already has been addressed. Material, electrical and economical considerations make LCP a serious candidate for all multichip modules (MCMs), SoPs and advanced packaging technology are led by the growing market for digital, RF and opto-RF applications. However, the fabrication of SISO dual-band filters and RF-MEMS switches extend the platform to multiband and reconfigurable applications.

Figure 1 shows the proposed module concept. Two stacked SoP mul-

	FR4	LTCC	LCP
Dielectric constant	4.5@1MHz	5.6@20GHz	3.0@20GHz
Loss Tangent	0.02	0.0012	0.002
CTE	15-20*10 <sup>-6</sup> /K	5.9*10 <sup>-6</sup> /K	3-17*10 <sup>-6</sup> /K
Cost	Very Low	Low/Medium	Low

\*Engineered

Table 1. Comparison of substrate properties.

# notable developments

tilayer substrates are used (for better isolation of the RF transmitter and receiver) and board-to-board vertical transition is ensured by  $\mu$ BGA balls. Standard alignment equipment is used to stack the board and to provide a compact, high-performance and low-cost assembly process. Multi-stepped cavities in the SoP boards provide spacing for embedded RF active devices (RF switch, receiver and transmit-

ter) chipsets, leading to significant volume reduction by minimizing the gap between the boards. Active devices can be flip chipped as well as wire bonded. Cavities also provide integration opportunities for MEMS devices such as switch, passive components. Off-chip matching networks, embedded filter and antenna are directly implanted into SoP boards using multilayer technology. Standard BGA balls ensure the

efficient interconnection of this high-density module with a motherboard, such as FR4 board. Top and bottom substrates are dedicated to the receiver and transmitter building blocks of the RF front-end module and are interconnected with  $\mu$ BGAs.

The receiver board includes antenna, band-pass filter, active switch RF receiver chipset (LNA, VCO and down-conversion mixer). The transmitter board includes RF transmitter chipset (up-converter mixer and power amplifier) and off-chip matching networks. Ground planes and vertical via walls address isolation issues between the transmitter and the receiver functional blocks. Arrays of vertical via are added to the transmitter board to achieve better thermal management.

## WLAN Modules

A functional RF compact module (volume of  $75 \times 35 \times 0.2 \text{ mm}^3$ ), compliant with the IEEE 802.11a WLAN applications incorporating LCP board technology, has been designed and measured. The architecture is a superheterodyne Tx/Rx system. Two passive mixers, achieving higher linearity, up-convert the low IF (20 MHz) OFDM signal to the 5.8 GHz frequency band and two BFP operations cancel the unwanted images after each mixing. Driver stages provide the gain needed to balance the losses from passives, while the PA module demonstrating a  $P_{1\text{dB}}$  of 30 dBm enables operation at a back off of 6 dB, which is a prerequisite for OFDM transmission. The receiver exploits a variable-gain LNA for linearity considerations. Inspection of the frequency spectrum of the signal at the output of the Tx module shows that leakage of the local oscillator signal is efficiently suppressed to 48 dBm, as well as the leakage of the unwanted image at LO2-LO1. The receiver's overall NF is lower than 8 dB to enable proper RF reception and then demodulation of signals as low as  $-i70\text{dBm}$ .

**AP**

## References

Please contact the authors for a complete list of references.

---

M.M. TENTZERIS et al. may be contacted at Georgia Tech's Packaging Research Center, School of Electrical and Computer Engineering, Georgia Institute of Technology, Atlanta, GA 30332-0269; e-mail: etentze@ece.gatech.edu.

For free data, enter 13 at [www.onlinecenter.to/ap](http://www.onlinecenter.to/ap)