

Novel Feeding Topologies for 2nd Harmonic Suppression in Broadband Microstrip Patch Antennas

*Il Kwon Kim¹, Jeong-II Kim³, Stephane Pinel²,
Joy Laskar², Manos M. Tentzeris², and Jong-Gwan Yook¹

¹Dept. of Electrical and Electronic Engineering, Yonsei University, Seoul, Korea, 120-749

²School of Electrical and Computer Engineering, Georgia Institute of Technology
Atlanta, GA 30332-0250, USA

³School of Electrical and Computer Engineering, Purdue University, West
Lafayette, IN 47907-2035
ik20@mail.gatech.edu

Abstract- In this paper, a fractal parallel coupled-line feeding structure is proposed to realize the 2nd harmonic suppression property, while allowing for a broadband operation of microstrip patch antennas. Numerical results have demonstrated that this type of fractal feeding can provide the antenna with a two times broader bandwidth compared to that of the conventional quarter-wavelength transformer feeding as well as a good 2nd harmonic suppression property.

I. Introduction

Microstrip patch antennas are very popular due to their easy and low-cost fabrications as well as due to its capability for easy integration with other circuits or multilayer modules. However, their large input impedance at the harmonic frequencies is a source of large harmonic components. These harmonic components can degrade the performance of the RF front end module due to the nonlinear property of integrated or embedded active components. Especially, the 2nd harmonic is critical in a direct conversion transceiver because it is located at near frequency zero and it can generate direct current (DC). Also, the impedance bandwidth of a microstrip patch antenna is inherently narrow. Microstrip patches on thin substrates can be considered as high Q resonators, which results in narrow bandwidth.

To overcome the high harmonic problem, several methods have been published and studied [1-4]. Among them, photonic band gap (PBG) and defected ground structure (DGS) are the most popular solutions. Due to the stop band and the slow wave property of these structures, harmonics of patch antennas are well suppressed. However, the problem of these structures is that they allow for a significant backside radiation, which is detrimental to the radiation characteristics. Moreover, these methods require the fabrication of additional structures at the bottom layer of 3D modules, which increases the fabrication cost. To solve these problems, microstrip patch antennas fed by fractal-shape parallel lines are proposed in this paper both to suppress the 2nd harmonic and to increase the impedance bandwidth.

II. Microstrip Patch Antenna Fed by Fractal Parallel Coupled Line

In [5], the parallel coupled line feeding structure has been adopted to increase the impedance bandwidth. In this paper, the proposed antennas are designed on liquid crystal polymer (LCP) substrate, which features several exceptional RF properties, such as low loss ($\tan \delta$ ranges from 0.002-0.004 for frequencies up to 110 GHz), flexibility and near hermetic nature (water absorption is less than 0.004%), as well as low cost [6]. For the antennas presented here, we use 9 mil thickness LCP substrates which permittivity is 3.1. The operating frequency of the antenna is 13.05 GHz and accordingly the frequency for

the 2nd harmonic is 26.1 GHz. Fig.1 shows the configuration of patch antenna fed by parallel coupled lines with fractal configurations. As reported in [5], the parallel coupled lines feeding structure can increase the impedance bandwidth of a single substrate conventional patch antenna and is especially convenient for antenna arrays. The physical dimensions for the parallel coupled feeding antennas for each fractal iterations are summarized in Table.1. The three microstrip patch antennas are shown in Fig 2. In this design, the patch antennas are fed by using Koch zero (K0), Koch 1st order (K1), and Koch 2nd order (K2) coupled line, respectively [7]. The iteration factor applied in coupled line is 1/4. The center frequency of each antenna for the first dominant mode is considered at 13.05 GHz and its 2nd harmonic frequency is 26.1 GHz. Table 2 depicts the final [do you mean the optimized?] dimensions of the coupled lines and the patches, while Figure 3 shows return loss results which have been obtained by using commercial moment method (MOM) simulator. As shown in Fig.3 a, the bandwidth of antennas for QW(quarter wave transformer), K0, K1, and K2 are 160 MHz, 350 MHz, 300 MHz, and 300 MHz, respectively. Also, as shown in Fig.3 b, the 2nd harmonics of K1 and K2 coupled line feeding case is greatly suppressed to almost 0 dB compared to QW case(return loss at harmonic is about 18dB) and K0(return loss at harmonic is about 13dB). Fig.4 shows the calculated radiation pattern for proposed antennas, which is similar to the conventional (quarter-wavelength fed) ones.

IV. Conclusions

In this paper, a new feeding topology for microstrip patch antennas using fractal parallel coupled-lines is proposed to increase the bandwidth and to suppress the 2nd harmonic component. Numerical results demonstrate that patch antennas with this novel feeding configuration can be used in systems which require broadband operation and significant 2nd harmonic suppression, like direct conversion receivers.

References

- [1] Y.J. Sung M.Kim, and Y.-S. Kim, "Harmonics Reduction With Defected Ground Structure for a Microstrip Patch Antenna," *IEEE Antennas and Wireless Propagation letters*, Vol.2, pp.111-113, 2003.
- [2] Y.Horri and M. Tsutsumi,"Harmonic control by photonic bandgap on microstrip patch antenna," *IEEE Microwave Guided Lett.*, vol.9, pp.13-15, Jan.1999.
- [3] Y.J. Sung and Y.-S. Kim, "An Improved Design of Microstrip Patch Antennas Using Photonic Bandgap Structure," *IEEE Transactions on antennas and propagation*, Vol.53, no.5, pp.1799-1804, May 2005.
- [4] S.K. Kwon, B.M. Lee, Y.J.Yoon, Y.S.Song and J.-G. Yook, "A Harmonic Suppression Antenna for an Active Integrated Antenna," *IEEE Microwave and Wireless Components Letters*, Vol.13, No.2,pp 1779-1803, Feb. 2003.
- [5] J.I.Kim and Y.J.Yoon, "Design of Wideband Microstrip Array Antennas Using the Coupled Lines," *IEEE Antenna and Propagation Symposium Digest*, vol.3, pp.1410-1413, July 2000, Utah.
- [6] Dane C. Thompson, Oliver Tantot, Hubert jallageas, George E. Ponchak, Manos M. Tentzeris, and John Papapolymerou, "Characterization of Liquid Crystal Polymer(LCP) Material and Transmission Lines on LCP Substrates from 30 to 110 GHz," *IEEE trans.on Microwave Theory and Techniques*, Vol.52, pp. 1343-1352, April 2004.
- [7] I.K.Kim, N.Kingsley, M.Morton, R.Bairavasubramanian, J.Papapolymerou, M.M. Tentzeris and J.-G.Yook, "Fractal Shaped Microstrip Coupled Line Bandpass Filters for Suppression of the 2nd Harmonic," *IEEE trans. on Microwave Theory and Techniques*, Vol.53, No.9, pp.2943-2948, September 2005.

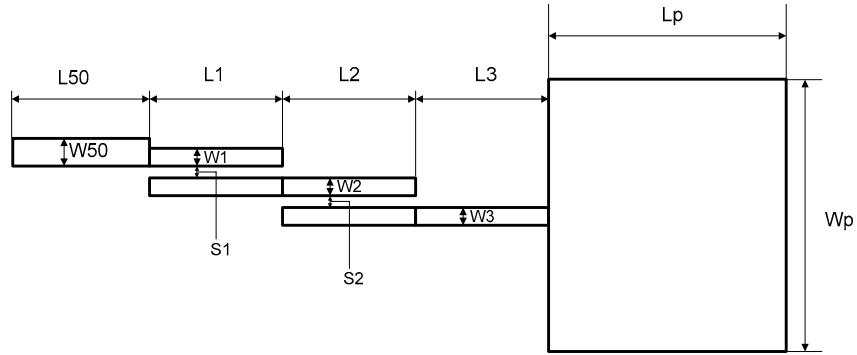

Fig.1. Physical dimensions for parallel coupled line feeding structure

Table.1. Summary of physical dimension of parallel coupled line section: unit [mm]

	L1	W1	S1	L2	W2	S2	L3	W3
K0	3.57	0.43	0.09	3.57	0.43	0.23	2.75	0.43
K1	3.57	0.43	0.09	3.57	0.43	0.27	2.75	0.43
K2	3.4	0.43	0.09	3.4	0.43	0.27	2.75	0.43

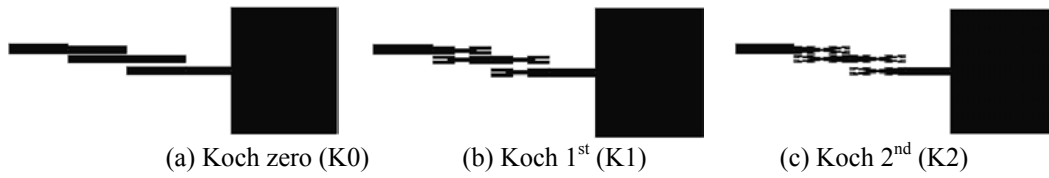
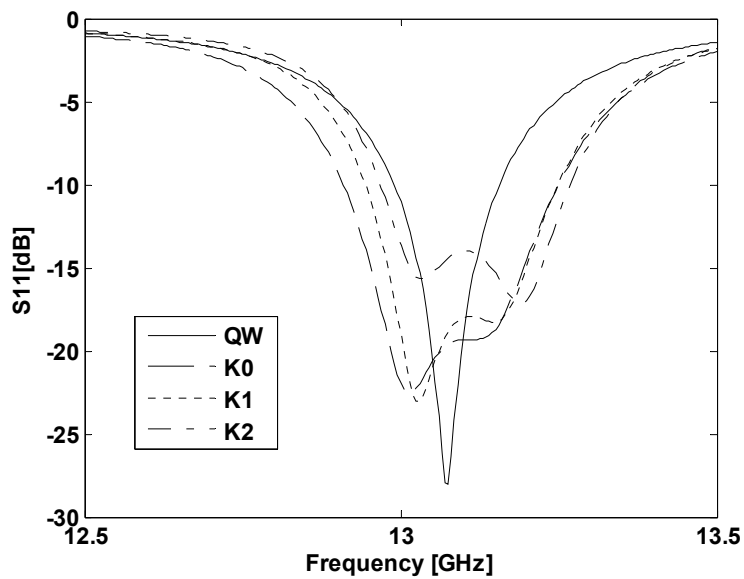
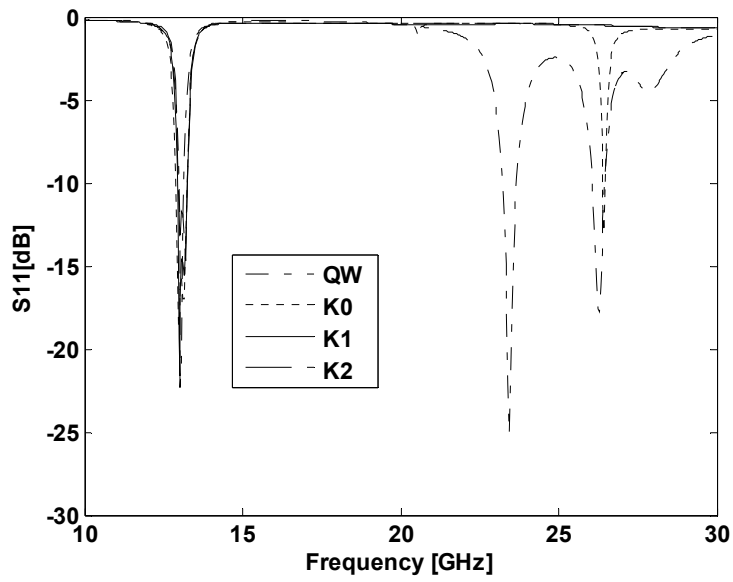

Fig.2. Configuration of proposed antennas



(a) 12.5 GHz-13.5 GHz



(b) 10 GHz – 30 GHz

Fig.3. Return loss property of proposed antennas

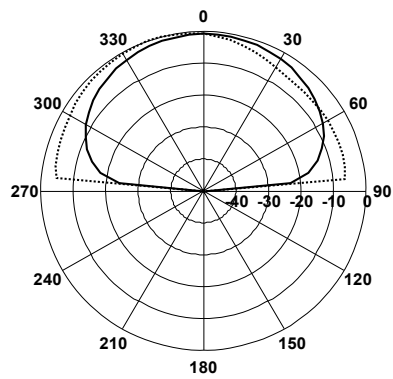

(a) Quarter wave transformer (QW)

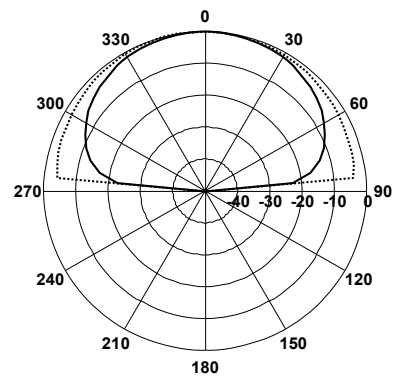

(b) Koch Zero (K0)

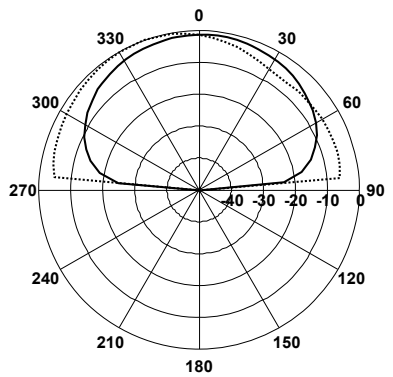

(c) Koch 1st (K1)

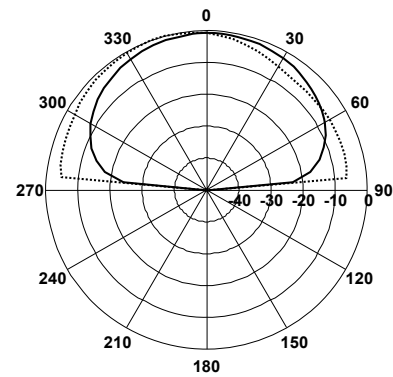

(d) Koch 2nd (K2)

Fig.4. Radiation pattern for proposed antenna at 13.25 GHz

(solid line: H-plane, dashed line: E-plane)